

Supply voltages do not need to be symmetric.

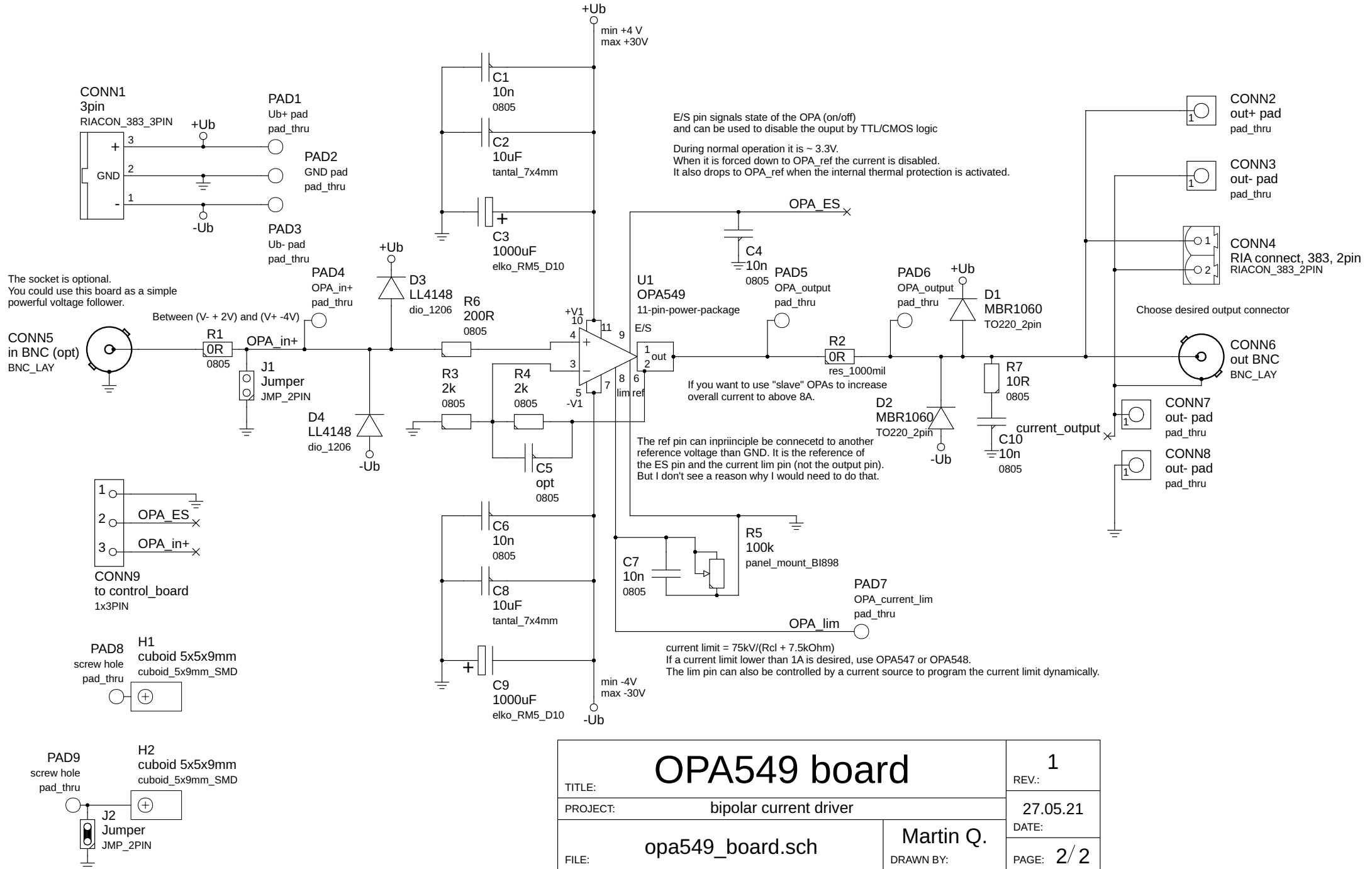

<h1>OPA549 board</h1>		1
TITLE:		REV.:
PROJECT: bipolar current driver		27.05.21
FILE: opa549_board.sch		DATE:
DRAWN BY: Martin Q.		PAGE: 2/2